

VAC STOP - Exploded View part numbers

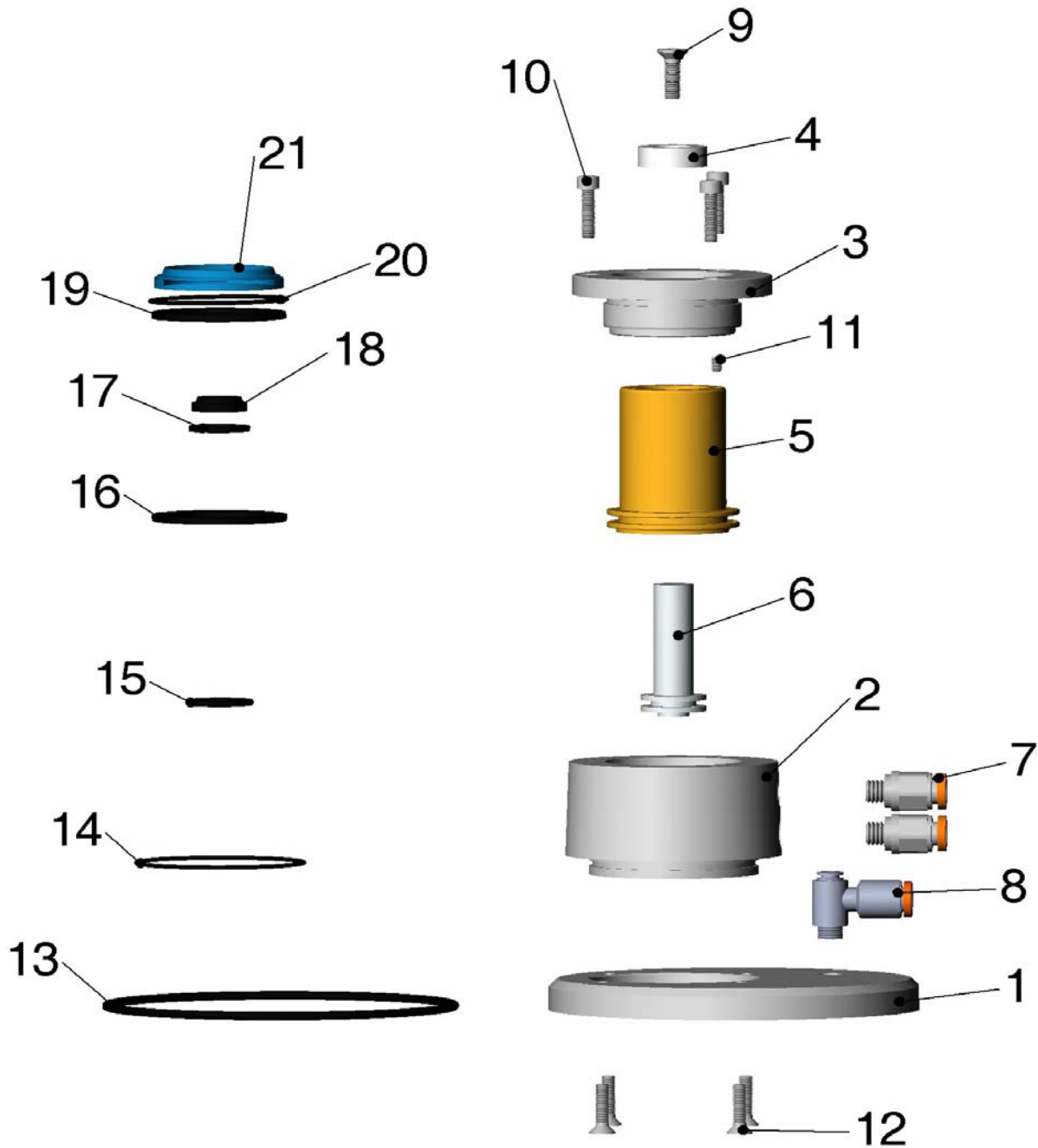

Part Number Reference

- | | |
|--------------------------|-----------------------------------|
| 1 - Base | 12 - Screw, M5x20 FH |
| 2 - Cylinder | 13 - Oring, Base, -250 |
| 3 - Retainer Ring | 14 - Oring, Base Cylinder, -32? |
| 4 - 26mm Disk | 15 - Seal, SS Piston OD |
| 5 - Brass Piston | 16 - Seal, Brass Piston OD |
| 6 - SS Piston | 17 - Seal, Brass Piston ID |
| 7 - Air Fitting Straight | 18 - Wiper Seal, Brass Piston ID |
| 8 - Air Fitting "L" | 19 - Seal, Retainer Ring ID |
| 9 - Screw, M6x6 FH | 20 - Oring, Retainer Ring, OD |
| 10 - Screw, M5x14 SH | 21 - Wiper Seal, Retainer Ring ID |
| 11 - Set Screw, M4x6 SH | |